



CITY OF LAREDO

BUILDING DEVELOPMENT SERVICES

1413 Houston St, Laredo, Texas, 78040 • Phone: 956.794.1625 • bldgpermits@ci.laredo.tx.us

Sign Permit Application

Applicant: _____ Owner: _____

Address: _____ Mailing address: _____

Telephone: _____ If corporation, Registered Agent: _____

Email: _____

THE FOLLOWING REQUIRED DOCUMENTS AND INFORMATION MUST BE PROVIDED WITH APPLICATION:

_____ Copy of Recorded Deed OR Lease Agreement

_____ Site Plan (see Plans Requirements)

_____ Elevation (see Plans Requirements)

Sign Type: Freestanding Wall/ Attached Banner LED Animated/ Digital¹ (requires S.U.P.)

Illuminated¹: Y N Setback: _____ Surface Area: _____ Height²: _____

LEGAL DESCRIPTION OF THE PROPERTY:

Location of proposed sign: _____ New Business Y N Permit# _____

Lot: _____ Block: _____ Subdivision: _____ Present Zoning: _____ Historic: _____

Allowable surface area allowed by ordinance: _____ sq ft Required Setback: _____ (Section 28-28.1-28.28.5)

Allowable surface area based on wall area: _____ sq ft Temporary weekend signs – attach a map of route to location

Overhead power lines: _____ Requires Sign Contractor (over 32 sq ft): _____ Requires Electrical Sign Contractor: _____

Notes: _____

I HEREBY CERTIFY THAT I HAVE READ AND EXAMINED THIS APPLICATION AND KNOW THE SAME TO BE TRUE AND CORRECT. ALL PROVISIONS OF LAWS AND ORDINANCES GOVERNING THIS TYPE OF WORK WILL BE COMPLIED WITH WHETHER SPECIFIED HEREIN OR NOT. THE GRANTING OF A PERMIT DOES NOT PRESUME TO GIVE AUTHORITY TO VIOLATE OR CANCEL THE PROVISIONS OF ANY OTHER STATE OR LOCAL LAW REGULATIONS CONSTRUCTION OR THE PERFORMANCE OF CONSTRUCTION. **PERMIT HOLDER IS RESPONSIBLE FOR SCHEDULING INSPECTIONS WITH THE BUILDING DEVELOPMENT SERVICES**

956.794.1626

Signature of Owner Date

Signature of Applicant Date

Issued by Date

No sign shall be installed in the City of Laredo Right-Of-Way (Sec 28_24(b))

If Applicant is different from the owner named on the deed, the affidavit must be completed

Fees. Sign review and permit fees shall be based on the total square footage of the proposed sign as follows:

1.	Review Freestanding ²	\$30
2.	Review Wall Signs	\$20
3.	Review Banners	\$20
4.	Review Animated Sign ¹	\$50
5.	Annual Animated Sign Inspection Fee	\$100
6.	Sign Permit Fee	\$0.55 per square foot
7.	Animated Sign Permit Fee	\$0.75 per square foot
8.	Electronic Message Display Permit Fee	\$0.75 per square foot
9.	Cross Street Banner Fee	\$75 per location
10.	Pull Down Banner Fee	\$10 per location
11.	Special Events Signs	\$75 per event
12.	Temporary weekend sign permit	\$50 per weekend
13.	Temporary weekend sign annual fee	\$500
14.	Feather Banner	\$20 per location per year

Email application to: bldgpermits@ci.laredo.tx.us

PLAN REQUIREMENTS

EXISTING 5' UTILITY EASEMENT

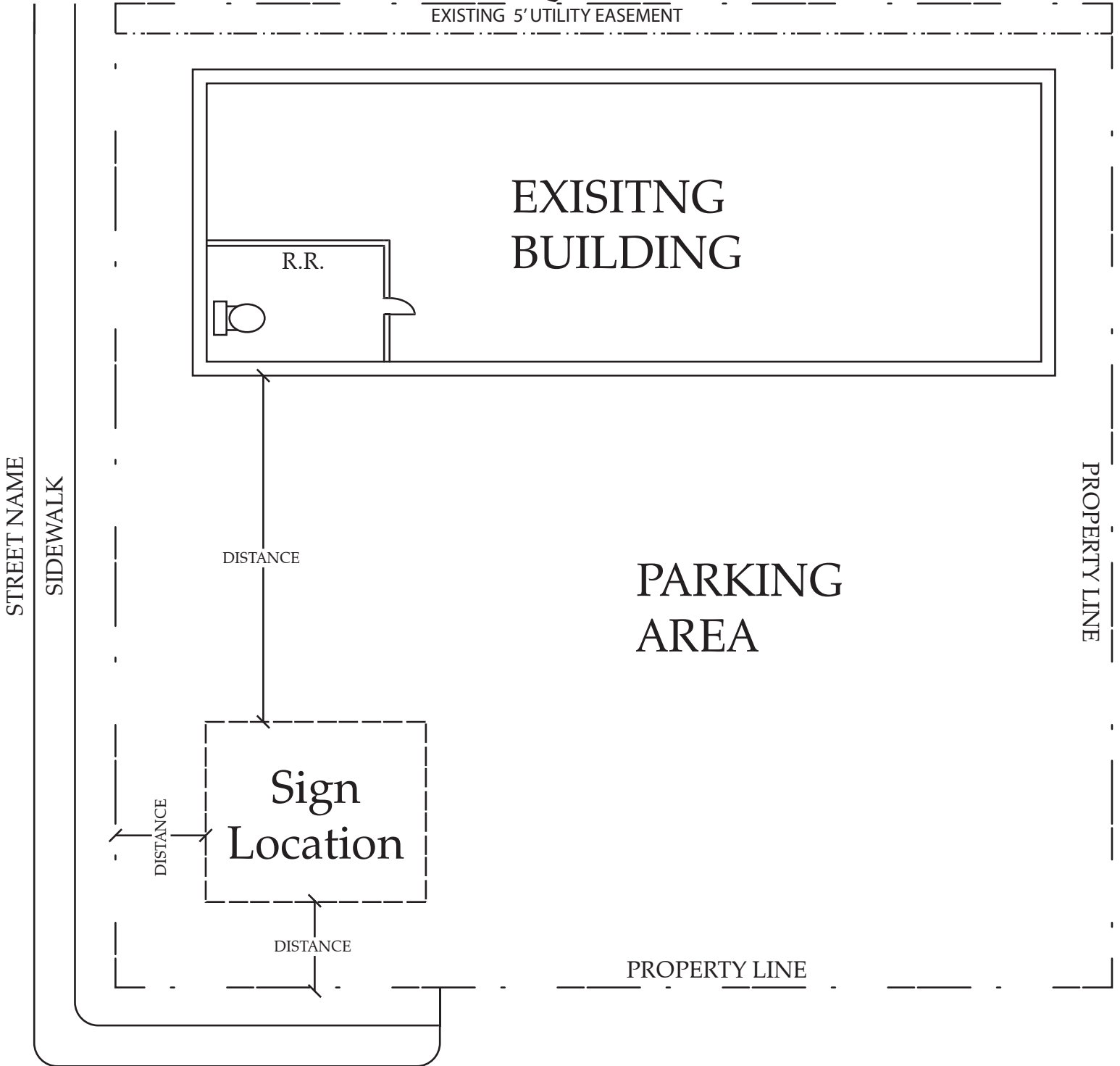

STREET NAME

SITE PLAN

ZONE: _____

SCALE:

ADDRESS: _____

LEGAL DESCRIPTION: _____

ALL SITE PLANS MUST INCLUDE: SIGN LOCATION IN REFERENCE TO PROPERTY LINE AND ALL BUILDING LOCATIONS. ALL EASEMENTS (UTILITY, ACCESS, DRAINAGE, ETC) MUST ALSO BE SHOWN.

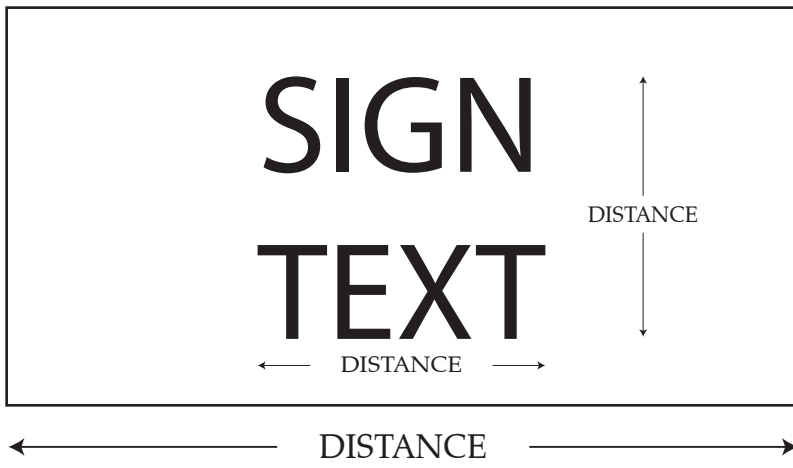

WALL SIGN

SIGN MATERIAL: _____
 TOTAL SQUARE FOOTAGE: _____

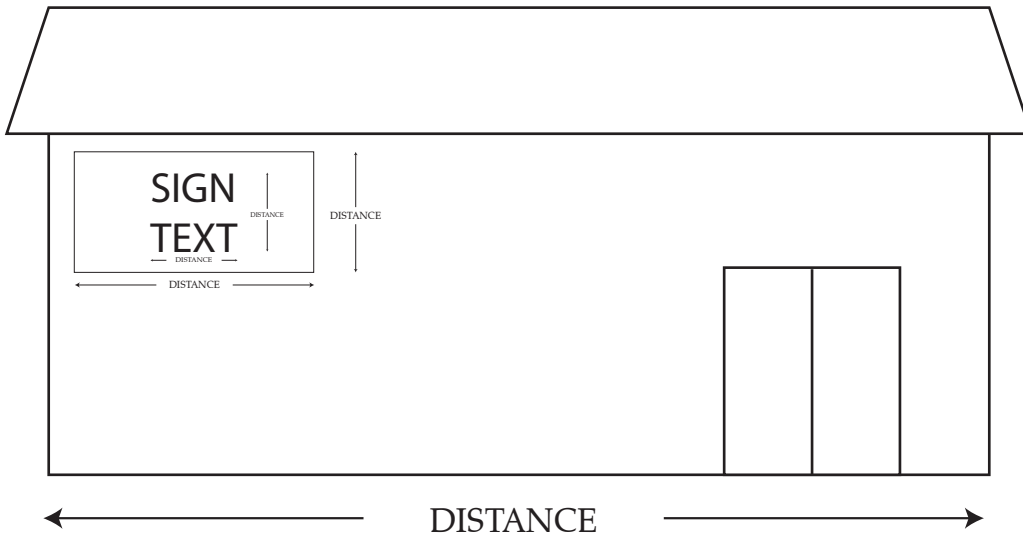
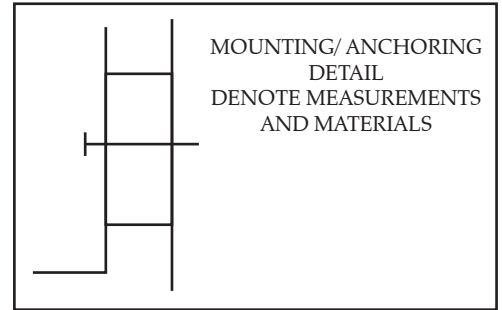

ELEVATION OF WALL SIGN ON BUILDING
 MAY ALSO USE PHOTOGRAPH

DISTANCE

DISTANCE

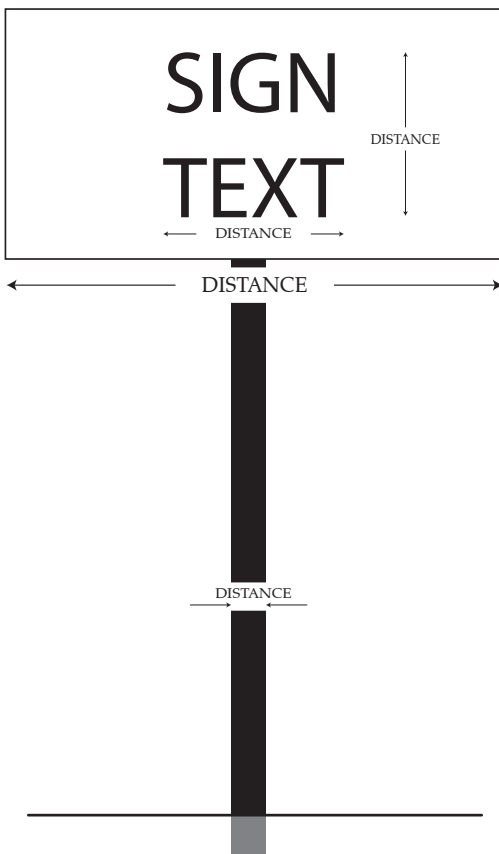

FREESTANDING SIGN

SIGN HEIGHT ABOUT GRADE LEVEL: _____
 FOOTING DEPTH: _____
 POLE MATERIAL: _____
 POLE WIDTH: _____

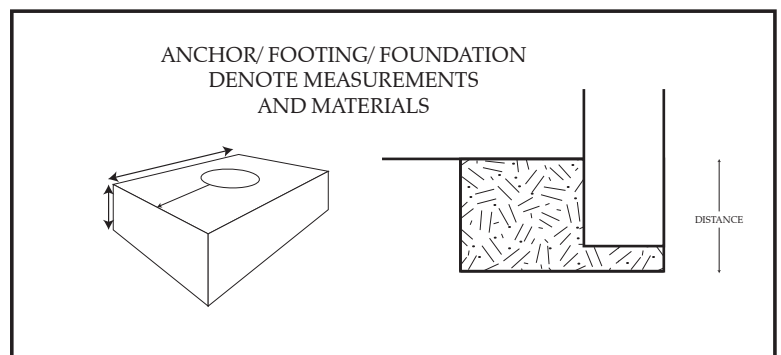

All sign applications that contain electrical components must provide electrical components specifications which must be Underwriters Laboratories (UL) approved or listed.

AFFIDAVIT

(Appointment of Representative)

STATE OF TEXAS§

COUNTY OF WEBB§

BEFORE ME, the undersigned authority, on this day personally appeared _____,
and first being duly sworn according to law upon his/her oath deposed and said:

“My name is _____; I am over eighteen (18) years of age and I reside at _____.
I am the legal owner (or authorized representative of the legal owner) of the property located at _____. I have designated _____ to represent me in applying for a sign permit with the Building Development Services Division of the City of Laredo, Texas. In relation to this, it is my understanding that as the owner of the aforementioned property, either I or my designated representative may apply for and obtain the sign permit. This authorization includes, but is not limited to, submitting plans, the application, and other documentation as may be required by the Building Development Services Division. I affirm that I have the legal authority to grant this permission and that all information provided herein is true and correct to the best of my knowledge. It has been explained to me and I understand that a written notice must be filed with the Director of Planning and Zoning for the City of Laredo, Texas, to give notice to the City of the termination or substitution of presentation for this sign permit.”

Affiant’s Signature

Affiant’s Name (Print)

On _____, 20____, personally appeared _____
and having been duly sworn by me, subscribed to the foregoing affidavit and has stated that the facts therein are true and correct.

Notary Public, State of Texas